

TRESU

TRESU FlexiPrint IMW

Compact Chamber Doctor Blade System

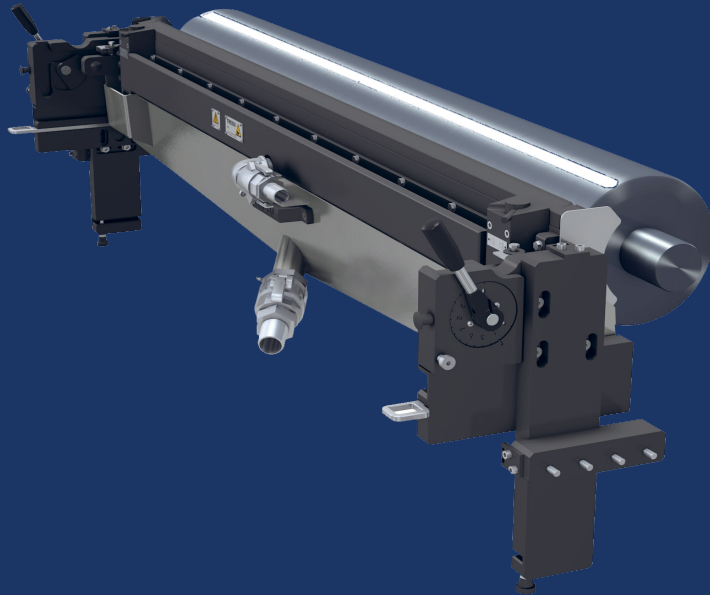

Meet TRESU at Hall 10B41

Streamlined and efficient chamber design for very easy handling

- TRESU FlexLoc mechanical positioning system
- Designed for mid web flexo machines
- Standardized, compact design with excellent price-performance ratio and low Cost-to-Print (CTP)
- Open flow- or pressure controlled ink and coating circulation
- Patented TRESU E-Line, P-Line or S-Line clamping system with fastest change of doctor blades and effective quality doctoring
- Patented TRESU end seals guaranteeing authentic quality
- WB, UV, solvent based inks and coatings

www.tresu.com - Sign up and stay connected



TRESU FlexiPrint IMW

Streamlined and efficient design



TECHNICAL SPECIFICATIONS

Anilox width	Up to 2.000 mm (78").
Anilox diameter	From 80 – 400 mm (3" – 15").
Speed	Up to 500 m/min - 1,640 ft/min Option: up to 800 m/min (2,624 ft/min) with high speed (HS) mechanical chamber positioning.
Print mode	Flow and pressure mode.
Clamping	E-Line quick clamping solutions or optional S-Line screw connections or optional P-Line connections.
Materials and surface	Aluminum with HA-S (Hard anodized w/o teflon) Aluminum with Ceraflex (protection against ink or coating and detergents with high and low ph-values. Carbon fiber CFC – Lightweight with protecting ink-repellent surface.
Ink/coatings	WB, UV or solvent based inks, coatings, glues etc.
Applications	Open flow circulation system. Pressure controlled ink/coating circulation with manual og closed loop control system, multiple in- and outlets. Inline circulation and / or high pressure cleaning.

TRESU FlexiPrint Chamber Doctor Blade System with patented genuine TRESU seals ensure perfect sealing.

Clamping system

E-Line: Eccentric, quick clamping solution for chamber widths up to 2.000 mm (78").

Option:

S-Line: Screw clamping solution for special coatings and glue.

Ink and coating circulation:

Open flow circulation or pressure controlled ink/coating circulation with manual or closed loop control system, multiple in- and outlets.

Surface and materials:

Aluminum with hard anodized surface treatment.

Aluminum with Ceraflex (CFX) surface treatment.

Carbon Fiber Material (CFC).

Other:

ATEX applications.